

Cable Float Level Switch



www.fine-tek.com



PRODUCT INTRODUCTION

DESCRIPTION

The Float Level Switch is made from chemical resistant polypropylene. It is durable, low-cost, and specially designed to assist with long range and multiple point level detection in liquids. It is also suitable for tanks containing pumps and granular solutions.

APPLICATION

FAC: Suitable for pump controlled systems
FAR/ P / D/ E: Suitable for pump controlled waste water with a low Specific Gravity (SG level).
FAS: High temperature solutions
FAL/ J: Cleaner water, and installation with smaller process connections.
It is suggested to apply Reed Switch contact models in PLC or DCS control.

WORKING PRINCIPLE

The Cable Float Level Switch is structured by using either micro switches proximity switches or reed switches to control the contact. It's user-friendly design is ideal for level measurement. The switches will transmit an ON or OFF contact signal output when the float rises and turns upwards. The switch contains a metal ball that can slide as the float position changes. For different water or solution temperatures, different float materials are available for selection. Plastic and stainless steel switches are the most common. The cable float level switch can not only be used in clear liquids but also can be used in granular liquids. Long distance detection points and multi-point contacts are also available. Cable float level switches can be applied in all water management, petrochemical, chemical industries. Other uses include: air-conditioner systems, drainage systems, most tanks or containers with level switch requirements.

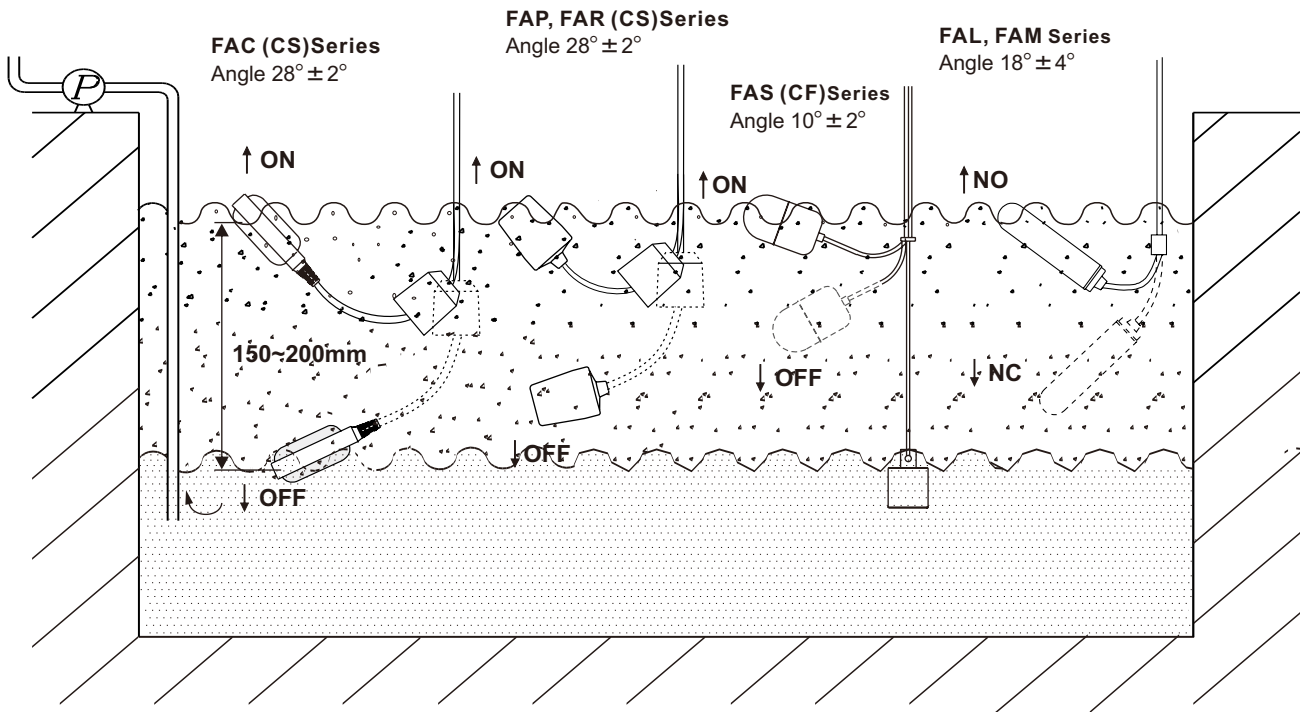

SPECIFICATIONS

Dimensions (Unit:mm)			
	FAC A/B/C Round type	FAP A/B/C Cup type	FAR A/B/C Cup type
Model	FAC A/B/C Round type	FAP A/B/C Cup type	FAR A/B/C Cup type
Switch	Micro switch	Micro switch	Micro switch
Float material	P.P.		
Cable spec	Neoprene Cable 1mm ² x3C or 2C	PVC Cable 1.25mm ² x3C or 2C	Neoprene Cable 1mm ² x3C or 2C
Contact rating	10A/ 250Vac (std.) or 15A/ 250Vac		
Contact form	N.O or N.C or SPDT		
Operating temp.	-10°C~80°C	0°C~60°C	-10°C~80°C
Specific gravity	0.6	0.6	0.6
Weight approx.	770g/5M	290g/1M	290g/1M
Pressure	2 kg/cm ²	2 kg/cm ²	2 kg/cm ²
Wire voltage	600 Vac	600 Vac	600 Vac
Isolation resistance	Min 100 MΩ		
Contact resistance	Max. 100mΩ+(70mΩ/m)		
Actuation angle	28° ± 2°	28° ± 2°	28° ± 2°
Protection	IP68	IP68	IP68

Float Type Code

FACA□□...PP Float

Cable length
 x6---0.6M 10--- 10M
 03--- 3M Max. 20M
 05--- 5M
 Contact form A--- N.O
 (Micro switch) B--- N.C
 C--- SPDT
 Cable material
 C ---Neoprene
 <HAR>HO7RN

FAPA□□...PP Float

Cable length
 x6---0.6M 10--- 10M
 03--- 3M Max. 20M
 05--- 5M
 Contact form A--- N.O
 (Micro switch) B--- N.C
 C--- SPDT
 Cable material
 P --- PVC

FARA□□...PP Float

Cable length
 x6---0.6M 10--- 10M
 03--- 3M Max. 20M
 05--- 5M
 Contact form A--- N.O
 (Micro switch) B--- N.C
 C--- SPDT
 Cable material
 R ---Neoprene
 <HAR>HO7RN

SPECIFICATIONS

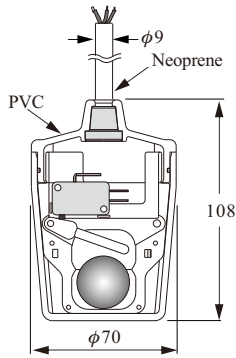
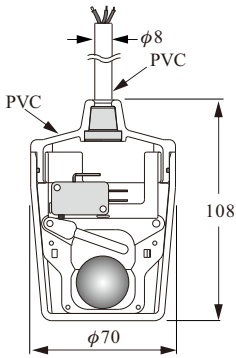
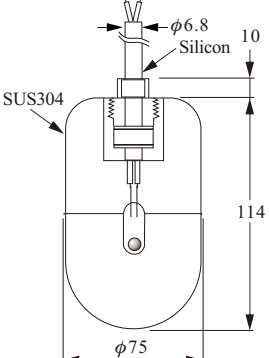
Dimensions (Unit:mm)			
	FAD A/B/C Round type	FAE A/B/C Cup type	FAS A/B/C Cup type
Switch	Micro switch	Micro switch	Mercury switch
Float material	PVC		SUS304
Cable spec	Neoprene Cable 1mm ² x3C or 2C	PVC Cable 1.25mm ² x3C or 2C	Silicon Cable 0.75mm ² x3C or 2C
Contact rating	10A/ 250Vac (std.) or 15A/ 250Vac		1A/ 230Vac
Contact form	N.O or N.C or SPDT		N.O or N.C or SPDT
Operating temp.	0°C~60°C	0°C~60°C	0°C~170°C
Specific gravity	0.6	0.6	0.5
Weight approx.	290g/1M	290g/1M	480g/5M
Pressure	2 kg/cm ²	2 kg/cm ²	2 kg/cm ²
Wire voltage	600 Vac	600 Vac	300 Vac
Isolation resistance	Min 100 MΩ		—
Contact resistance	Max. 100mΩ+ (70mΩ/m)		Max. 1Ω+ (70mΩ/m)
Actuation angle	28° ± 2°	28° ± 2°	10° ± 2°
Protection	IP68	IP68	IP68

Float Type Code

FADA□□...PVC Float

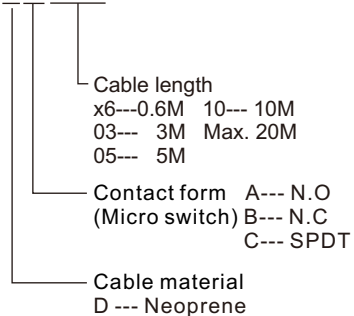

FAEA□□...PVC Float

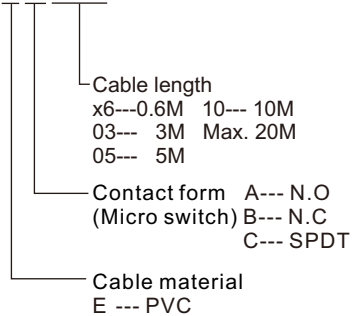

FASA□□...SUS Float

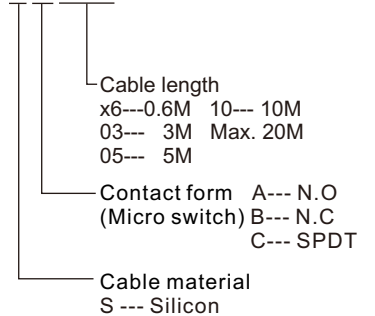

SPECIFICATIONS

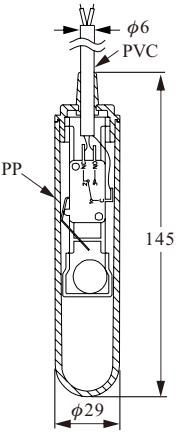
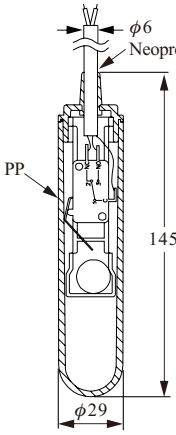
Dimensions (Unit:mm)		
	Model	FAL A/B/C Bar type
Switch	Micro switch	
Float material	P.P.	
Cable spec	PVC Cable 0.75mm ² x3C	Neoprene Cable 0.75mm ² x3C
Contact rating	3A/ 125/250Vac	
Contact mode	N.O or N.C or SPDT	
Operating temp.	-0°C~60°C	-10°C~80°C
Specific gravity	0.8	
Weight approx.	113 ± 2g/1M Cable	
Pressure	4.5 kg/cm ²	
Wire voltage	600 Vac	
Isolation resistance	Min 100 MΩ	
Contact resistance	Max. 100mΩ + (70mΩ/m)	
Actuation angle	Up 18° ± 4° / Down 3° ± 3°	
Protection	IP68	

Float Type Code

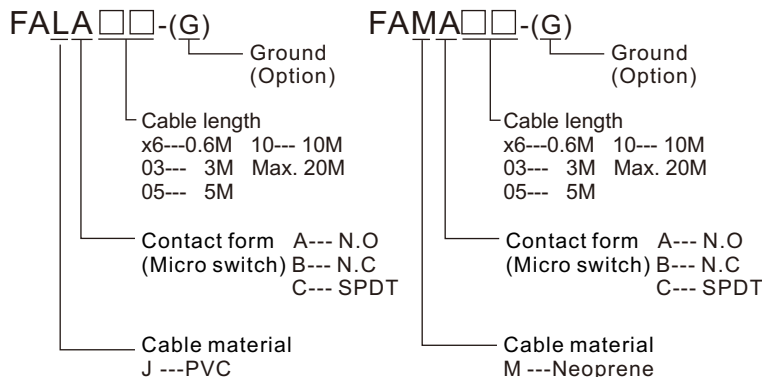

SPECIFICATIONS

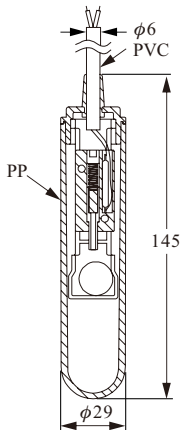
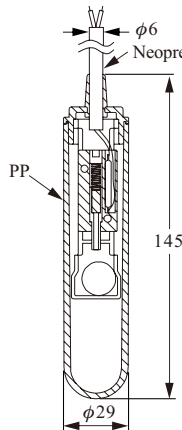
Dimensions (Unit:mm)		
	Model	FAJ A/B/C Bar type
Switch	Reed Switch	
Float material	P.P.	
Cable spec	PVC Cable 0.75mm ² x3C	Neoprene Cable 0.75mm ² x3C
Contact rating	AC70 VA / DC50 W(N.O), 20W(N.C, SPDT)	
Contact mode	N.O or N.C or SPDT	
Operating temp.	-0°C~60°C	-10°C~80°C
Specific gravity	0.8	
Weight approx.	115 ± 2g/1M Cable	
Pressure	4.5 kg/cm ²	
Wire voltage	300 Vac/ 350Vdc(N.O), 150 Vac/ 200Vdc(N.C, SPDT)	
Isolation resistance	Min 100MΩ	
Contact resistance	(N.O) Max.100mΩ+(70mΩ/m),(N.C,SPDT) Max.150mΩ+(70mΩ/m)	
Actuation angle	Up 18° ± 4° / Down 3° ± 3°	
Protection	IP68	

Float Type Code

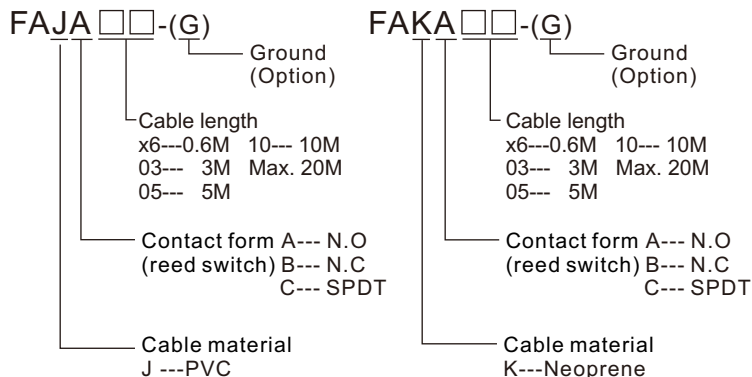

WEIGHTS DIMENSIONS

**FAPW-03
FAPW-05**

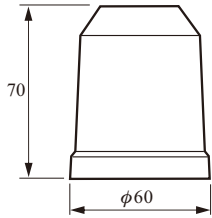

FASW

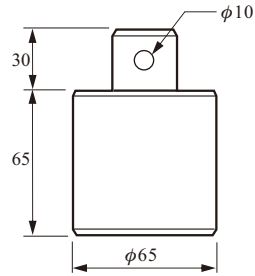

FAB-0010

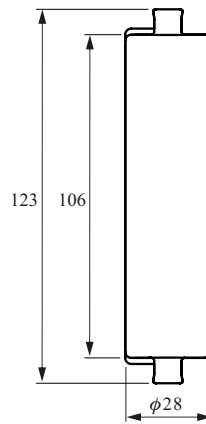

Model	Material	Weight
FAPW-03 FAPW-05	PP	0.3kg 0.5kg
FASW	SUS304	1.8kg
FAB-0010	PP	0.15kg

CONTACT MODE

1. SPDT (N.O)

FACA

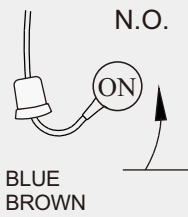

FAPA/FAEA

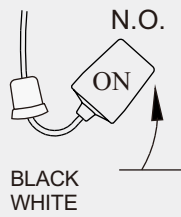

FARA/FADA

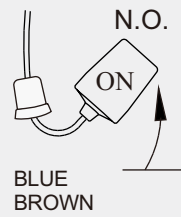

FASA

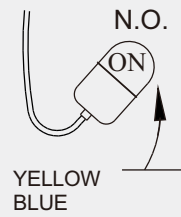

2. SPDT (N.C)

FACB

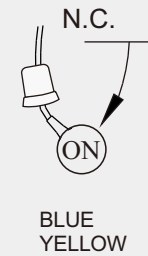

FAPB/FAEB

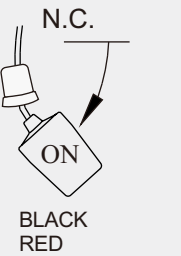

FARB/FADB

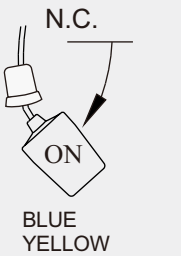

FASB

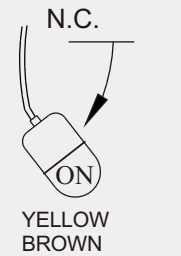

3. SPDT (1C)

FACC

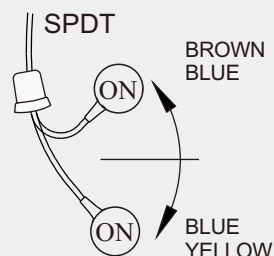

FAPC/FAEC

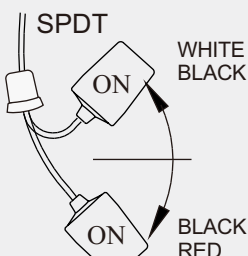

FARC/FADC

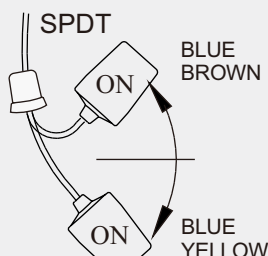

FASC

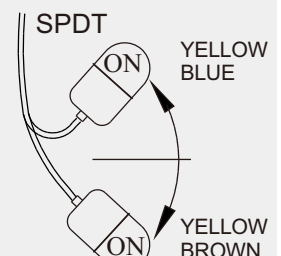

WIRING

Micro Switch

When the float hasn't contacted the liquid, the blue and black wires are in an open state and the contact mode will be NC. When the liquid level rises and lifts the float until it reaches the actuation angle, the brown and black wires will be in an open state and the contact mode will be NO.

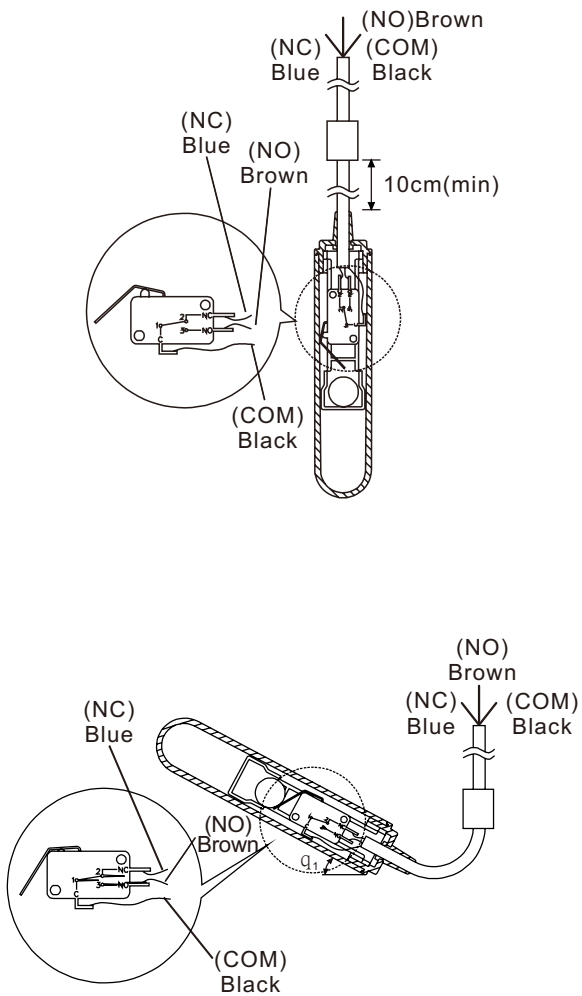

Reed Switch

When the liquid level is low, the metal ball remains away from the sensing range and the brown and black wires are in an open state (NC mode). When the liquid level rises and lifts the float until it reaches the actuation angle, the brown and black wires will be in an open state (NO mode).

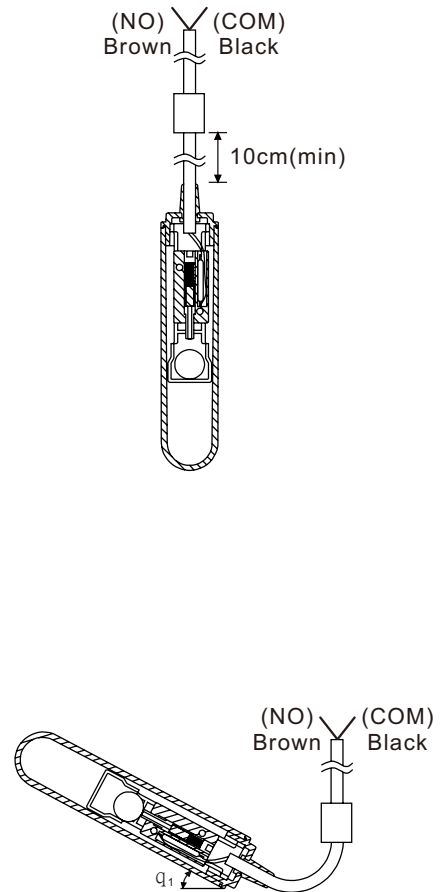

Installation guide

DIMENSIONS

The float's action length (a) must be shorter than the distance between the wall and the cable (A) ; if not, it will not function accurately.

The lowest float level (d) must be higher than the lowest water level of the pump (D).

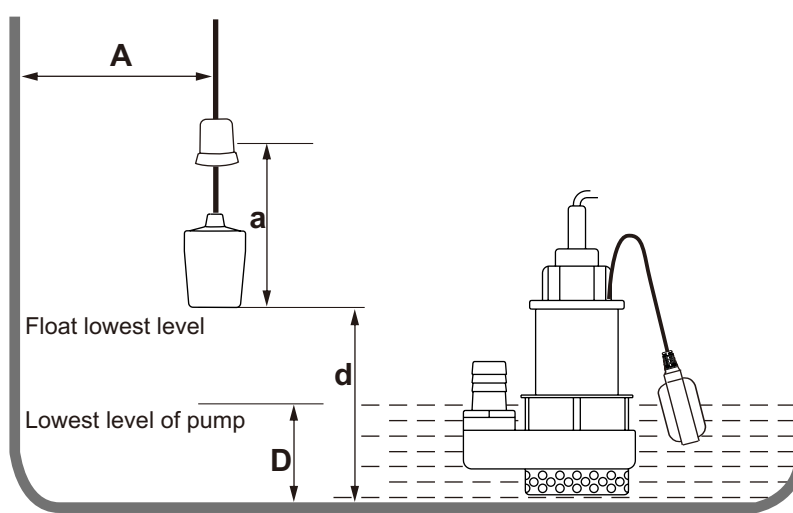

PRECAUTIONS

Keep a proper distance between the installation position and the water pump inlet to prevent the float switch from being sucked in towards the pump.

There should be a proper distance between the installation position and water inlet to prevent any direct water impact. If it can't be avoided, please install a pipe-shield or plate that lowers the turbulence.

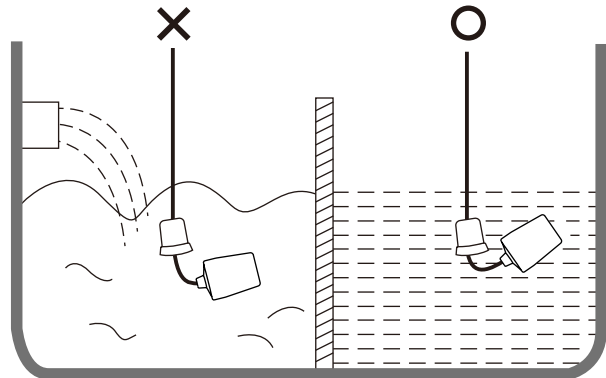
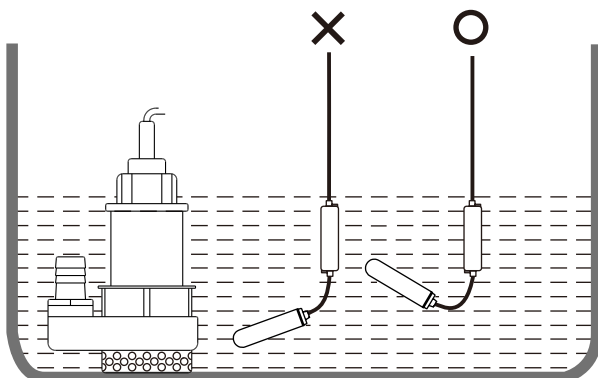

APPLICATION

The FBB type is suitable for installation from the tank's roof/top for level control and monitoring.

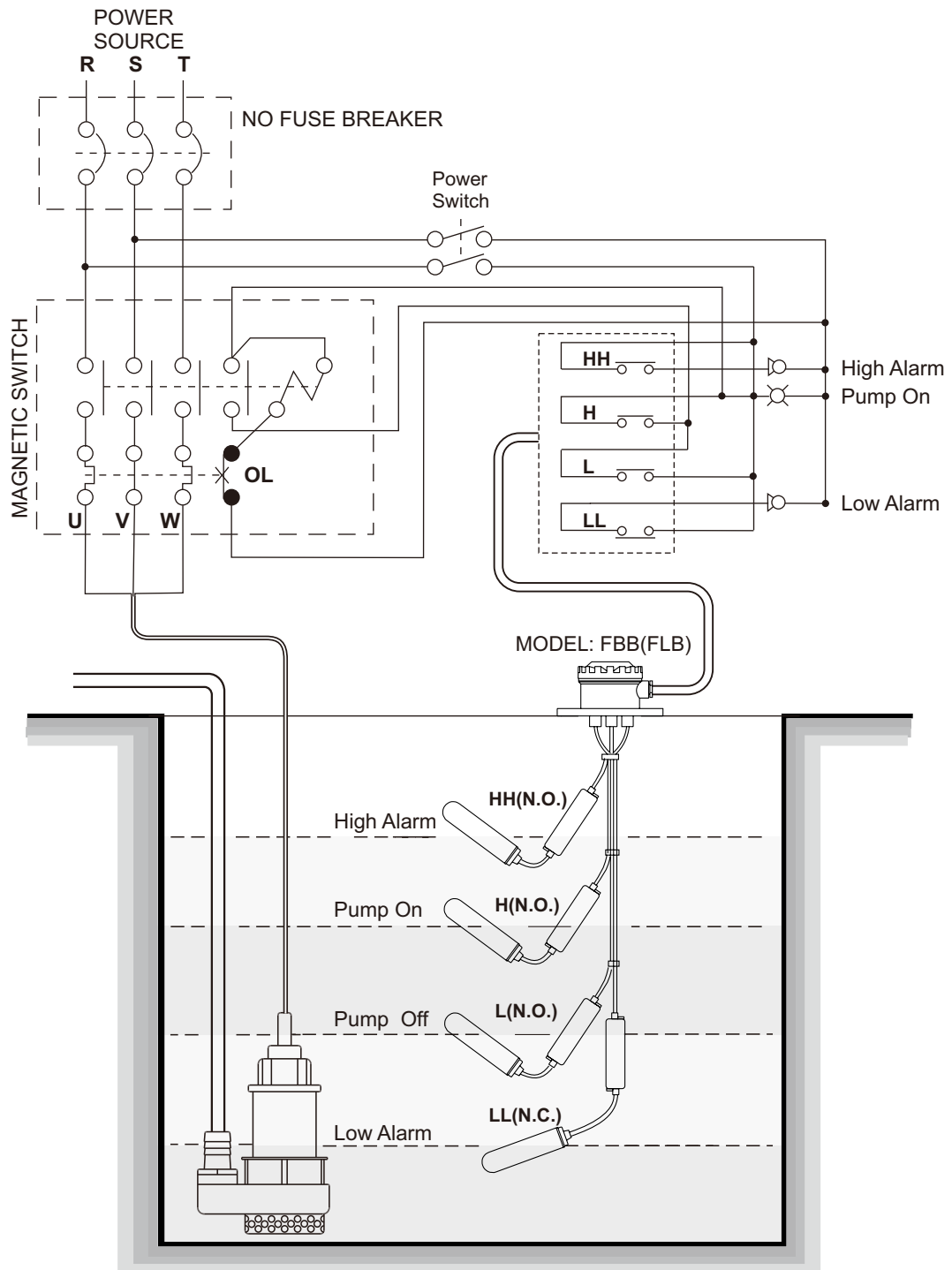

HOW TO ORDER CABLE FLOATS (FB TYPE)

Various types of multi-point products can be selected to meet the user's needs.

For example:
 FB-B type is suitable for corrosive solutions.
 FB-A type is suitable for high-temperature waste water

DISTANCE OF CONTROL POINTS

		NO	NC
ℓ 1 : _____ mm	<input type="checkbox"/>	<input type="checkbox"/>	<input type="checkbox"/>
ℓ 2 : _____ mm	<input type="checkbox"/>	<input type="checkbox"/>	<input type="checkbox"/>
ℓ 3 : _____ mm	<input type="checkbox"/>	<input type="checkbox"/>	<input type="checkbox"/>
ℓ 4 : _____ mm	<input type="checkbox"/>	<input type="checkbox"/>	<input type="checkbox"/>
L : _____ mm			

FB ()

Cable Fixed Wire Length (unit: mm)
 0500: 500mm up
 1000: 501~1000mm
 1500: 1001~1500mm
 ※ 500mm per Unit
 ※ Use English letter as first code for probe length over 10m.
 A150 represents 15m, A200 represents 20m

Cable Fixed Wire Material
 S: Stainless N: Nylon

Weight Quantity
 1~4

Weight Material
 C: P.P. P: PPφ28x106
 S: SUS304

Float Quantity
 1~4

Float material
 C: P.P. (φ90x110 Neoprene cable) L: P.P. (φ29x145 PVC cable)
 P: P.P. (φ70x108 PVC cable) M: P.P. (φ29x145 Neoprene cable)
 R: P.P. (φ70x108 Neoprene cable) G: P.P. (φ29x145 PVC cable)
 S: SUS(φ75x114 Silicon cable) H: P.P. (φ29x145 Neoprene cable)
 D: PVC(φ70x108 Neoprene cable) J: P.P. (φ29x145 PVC cable)
 E: PVC(φ70x108 PVCcable) K: P.P. (φ29x145 Neoprene cable)

Housing
 A: Aluminum B: Plastic S: SUS304

MODEL: FBA (FLA)

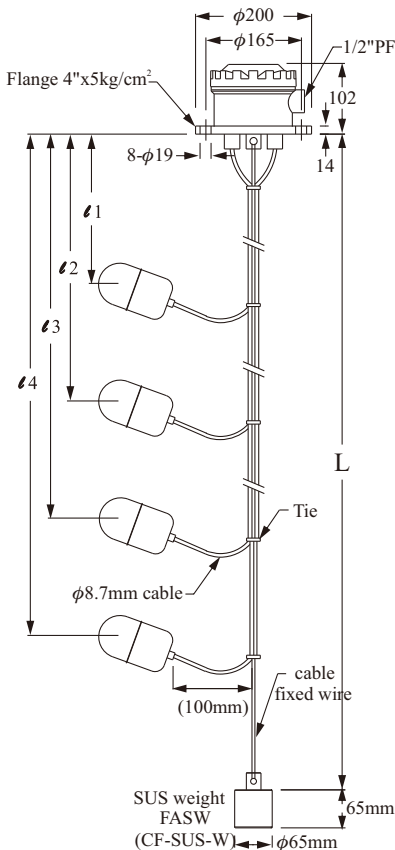

MODEL: FBB (FLB)

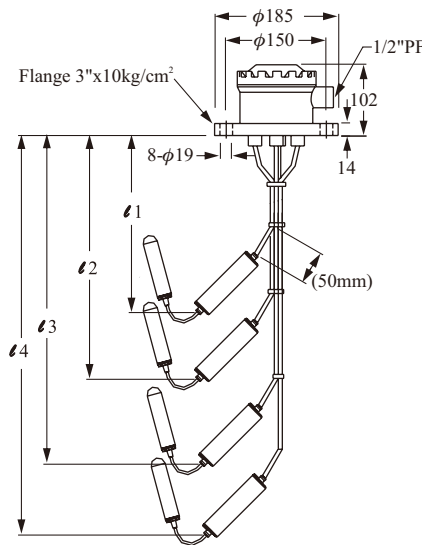

MODEL: FBS (FLB)

